

1.1 Test setup

Goal is to find typical performance values of the Resistive Linear Sensor (RLS) in cryogenic conditions. To do so an RLS is fitted on a CBS10 cryogenic positioner and motion is detected with both the RLS and an interferometer. The complete setup is placed in a cryostat achievable of reaching temperatures below 7K. All tests have been performed under realistic user conditions; in a lab environment, with running cryocooler (Gifford-McMahon type) and representative cabling. The RLS data are read using the Resistive Sensor Module (RSM) which can be slotted into JPE's standard electronics cabinet.

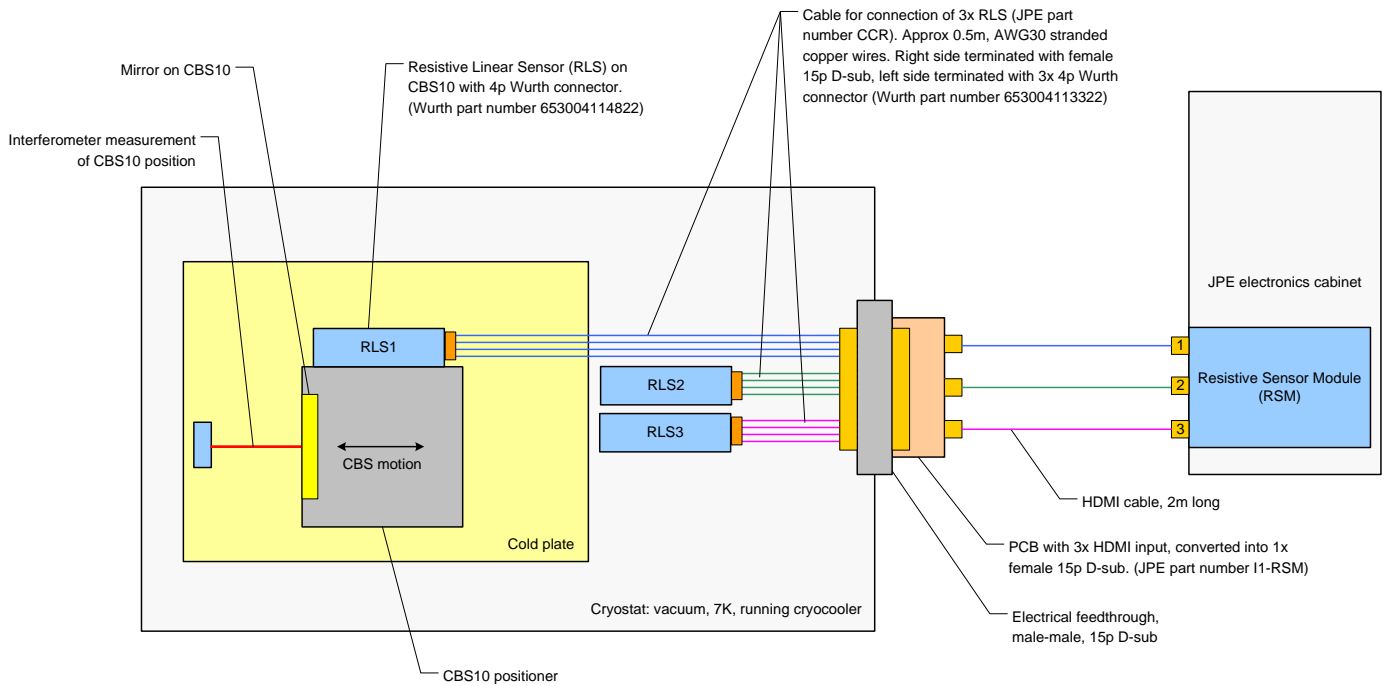

Fig 1: showing the used test setup

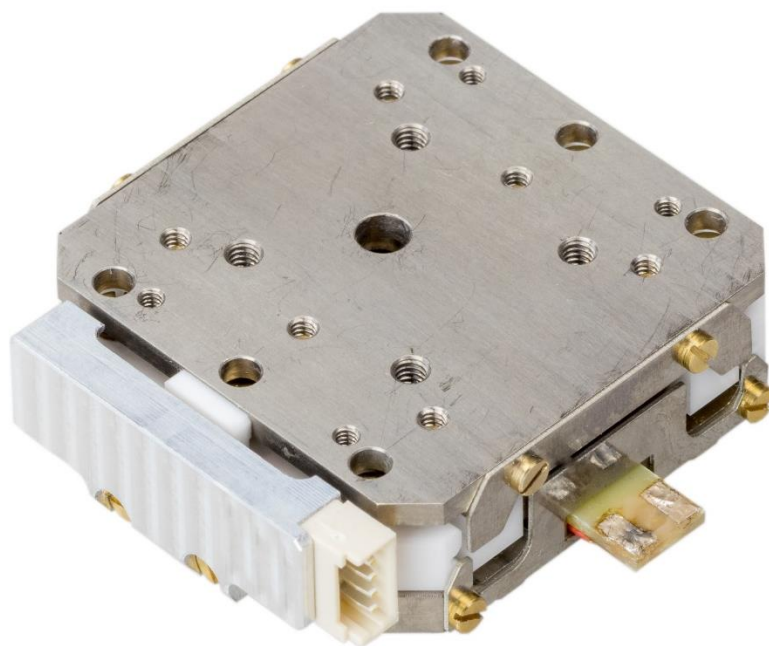

Fig 2: showing the CBS10 positioner with RLS at the left

1.2 Resolution

The resolution is defined as the smallest incremental step one can detect. It is fundamentally limited by the electrical noise of the RLS-RSM combination, as shown in Fig 3. This static measurement shows the mean readout "0" and the noise distribution around that mean value. The 25Hz filtered data is taken from the RSM and therefore most representative, but for completeness the unfiltered 5kHz data is shown also. A typical way of defining resolution is to take the 3σ value of the noise, which states that nearly all measured values (99.7%) will lie within three standard deviations of the mean. In this case $3\sigma = 78$ nm. The peak-peak value corresponds to $\pm 3\sigma = \pm 78$ nm. Sometimes the less stringent 1σ , or rms, value is used. In this case $1\sigma = 26$ nm value (68%).

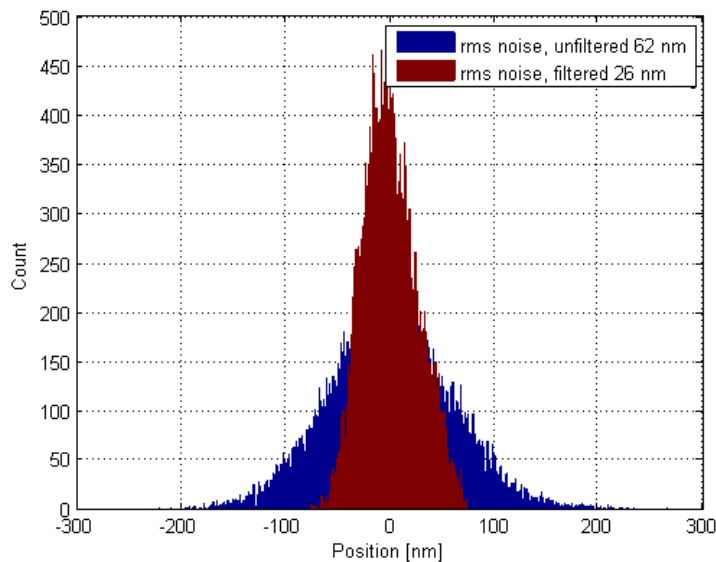

Fig 3: showing the noise distribution of the RLS-RSM combination.

1.2.1 Sinusoidal motion experiment

This experiment does not define a specification but provides a fair representation of the practical behavior of the RLS within the sub-micron range. It can be interpreted as the practical threshold of the operational capabilities of the RLS.

The experiment performed consists of moving the CBS10 positioner in a sinusoidal fashion utilizing the scanning functionality of the CBS10. Fig 4 shows the measured results when the CBS10 moves with a set amplitude of 100nm. As the picture indicates, the RLS follows the interferometer signal smoothly. The 2Hz cryocooler pulses are clearly visible on both the RLS and the interferometer signals. More prominent on the RLS signal because that is an off-axis measurement and includes Abbe errors.

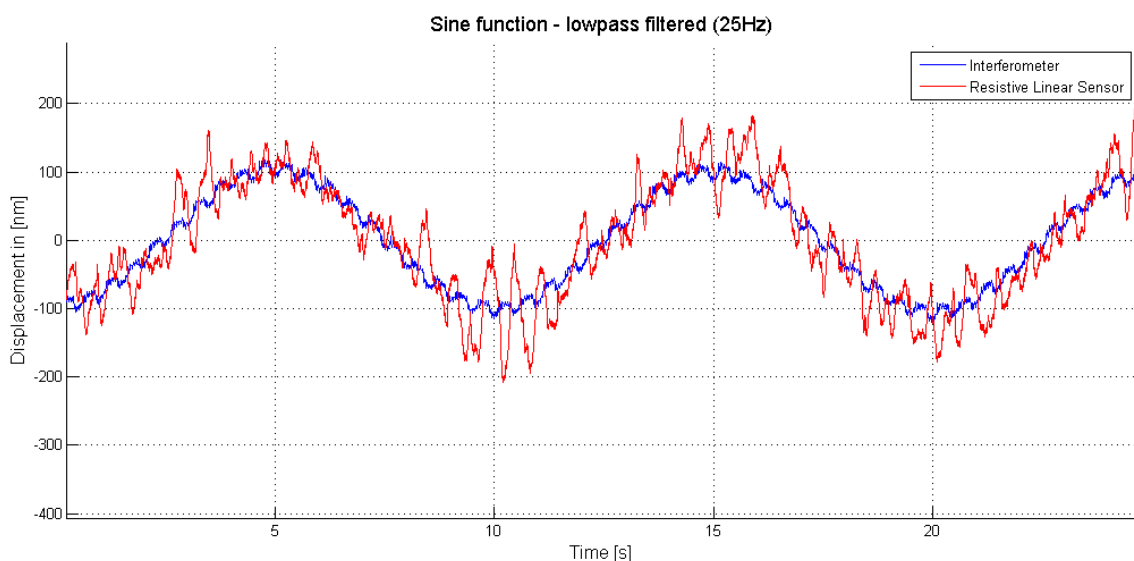
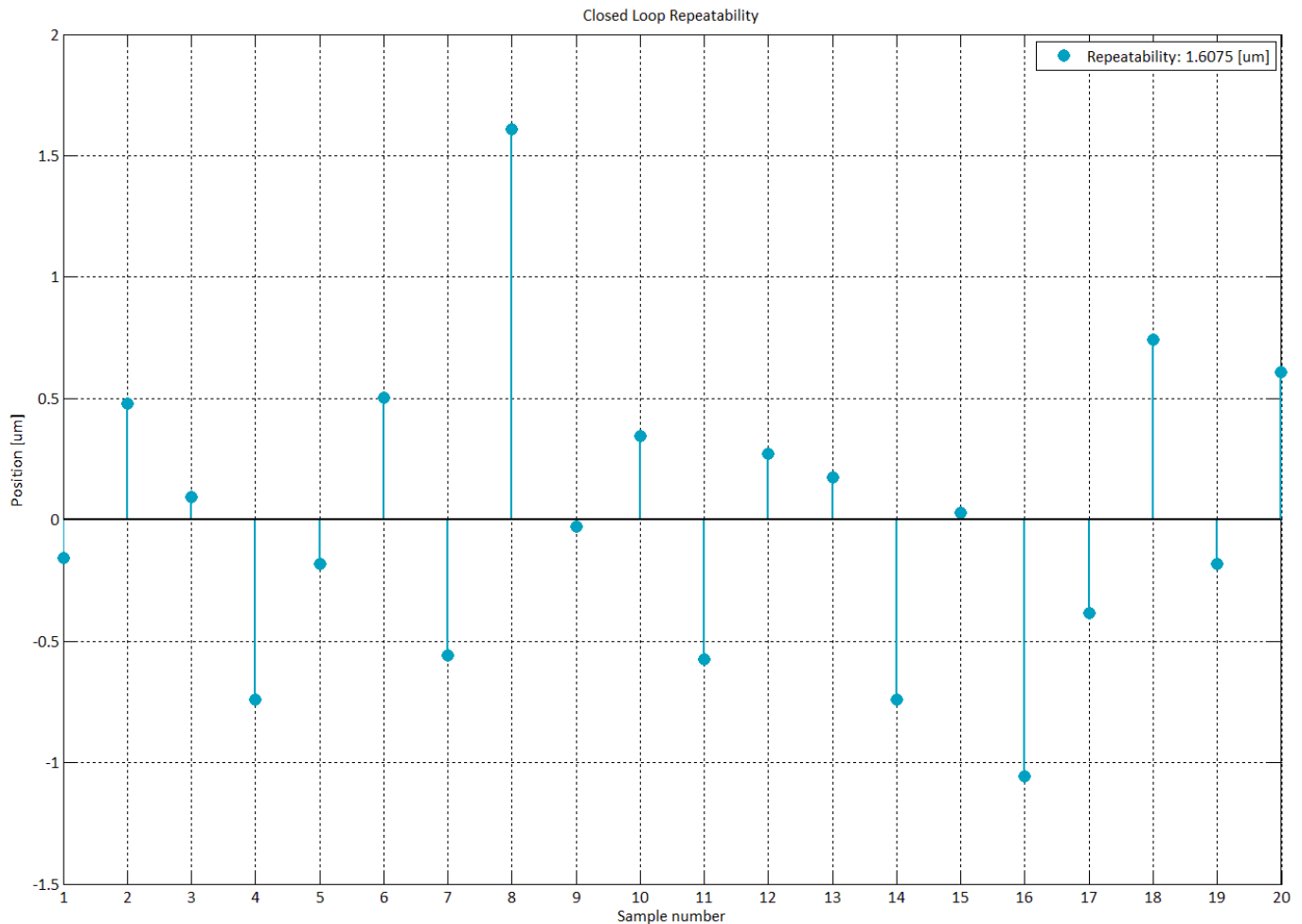

Fig 4: Sinusoidal motion experiment where the interferometer signal is blue and the RLS red.

1.3 Repeatability

During this experiment the repeatability of positioning is investigated at a temperature of approximately 10K. The CBS10 with RLS is moved 20 times to the same position under closed loop control. The even numbers correspond to an approach from the left, the odd numbers from the right and the zero position represents the median value. The actual position is measured by a second independent measurement system; an interferometer.



If sub-micron positioning is required, then the RLS works well in conjunction with the scan-range function as shown in experiment 1.2.1.