

APPLICATION NOTE

CRYO & NANO PRODUCTS – CONNECTION OVERVIEW

1. INTRODUCTION

Although all information in this application note is also available in the individual product user manuals, interface drawing and brochures, it is helpful to have a simplified but clear connection overview of how to connect JPE's Cryo & Nano *positioners* to the Cryo Positioning Systems *Controller 1* (CPSC₁) unit.

This application note strives to help anyone who is in process of setting up JPE's Cryo & Nano products, or is considering JPE's Cryo & Nano products for use in an upcoming project.

1.1 Cryo & Nano Products overview

Typical positioners, stages or scanners are:

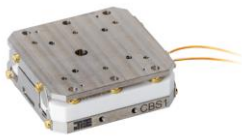

CBS



CLA



CS02



CLS

A typical controller is:



CPSC₁

Note: a controller consists of a base cabinet (CAB₁) with various plug-in modules (CADM₂, RSM, OEM₂, PSM) installed.

Available cables and connection kits as described in this application note:



ACL¹



I1-ACL²



CCL³



I1-RSM



CCR



AF5⁴

¹ Default length is 3m, but can be longer or shorter upon request (to be ordered as custom article)

² The I1-ACL can connect up to 6x ACL

³ Order code CCL6 for up to 3 positioners, or order code CCL12 for up to 6 positioners. CCL15-OE is a cable with 15 open-ended Kapton wires.

⁴ Default length is 3m, but can be longer or shorter upon request (to be ordered as custom article)

APPLICATION NOTE

CRYO & NANO PRODUCTS – CONNECTION OVERVIEW

1.2 Connection scenarios

There are a few connection scenarios, largely depending on whether positioners will be used in a cryo-vacuum environment or not:

- 1 Connecting positioners directly to the controller, without having to use a cryo-vacuum feedthrough. In this scenario, positioners are not yet – or don't need to be – installed inside a cryo-vacuum environment. Let's call this the **Direct Connection setup** (see Chapter 2).

For this scenario JPE can supply all required cabling and connectors so the customer can get up and running quickly without much hassle.

- 2 Connecting positioners to the controller using a cryo-vacuum feedthrough. In this scenario, positioners have been installed inside a cryo-vacuum environment. Let's call this the **Feedthrough Connection setup** (see Chapter 3).

For this scenario JPE can supply cabling and connectors based on industry standard 15p male-male D-SUB type feedthroughs and industry standard optical feedthroughs. The customer only needs to purchase and install these feedthroughs (and cryo optical fibers, if applicable).

- 3 Because there are many options in feedthroughs and types of wiring, it is also possible for customers to arrange, manufacture or assemble their own wiring to connect to different types of feedthroughs.

For this scenario JPE can offer limited support by supplying breakout boards with "open ends", typically in the form of solder pads, for example to make interfacing with (electrical) sensor connections easier. It is important to understand that everything else in this connection scenario is up to the responsibility of the customer. See chapter 4 for more information.

Furthermore, positioners can have various options, mostly related to a *feedback sensor* (optical or electrical) or *scanning* functionality. These various types of configurations will be discussed as well for each scenario.

APPLICATION NOTE

CRYO & NANO PRODUCTS – CONNECTION OVERVIEW

2. DIRECT CONNECTION SETUP

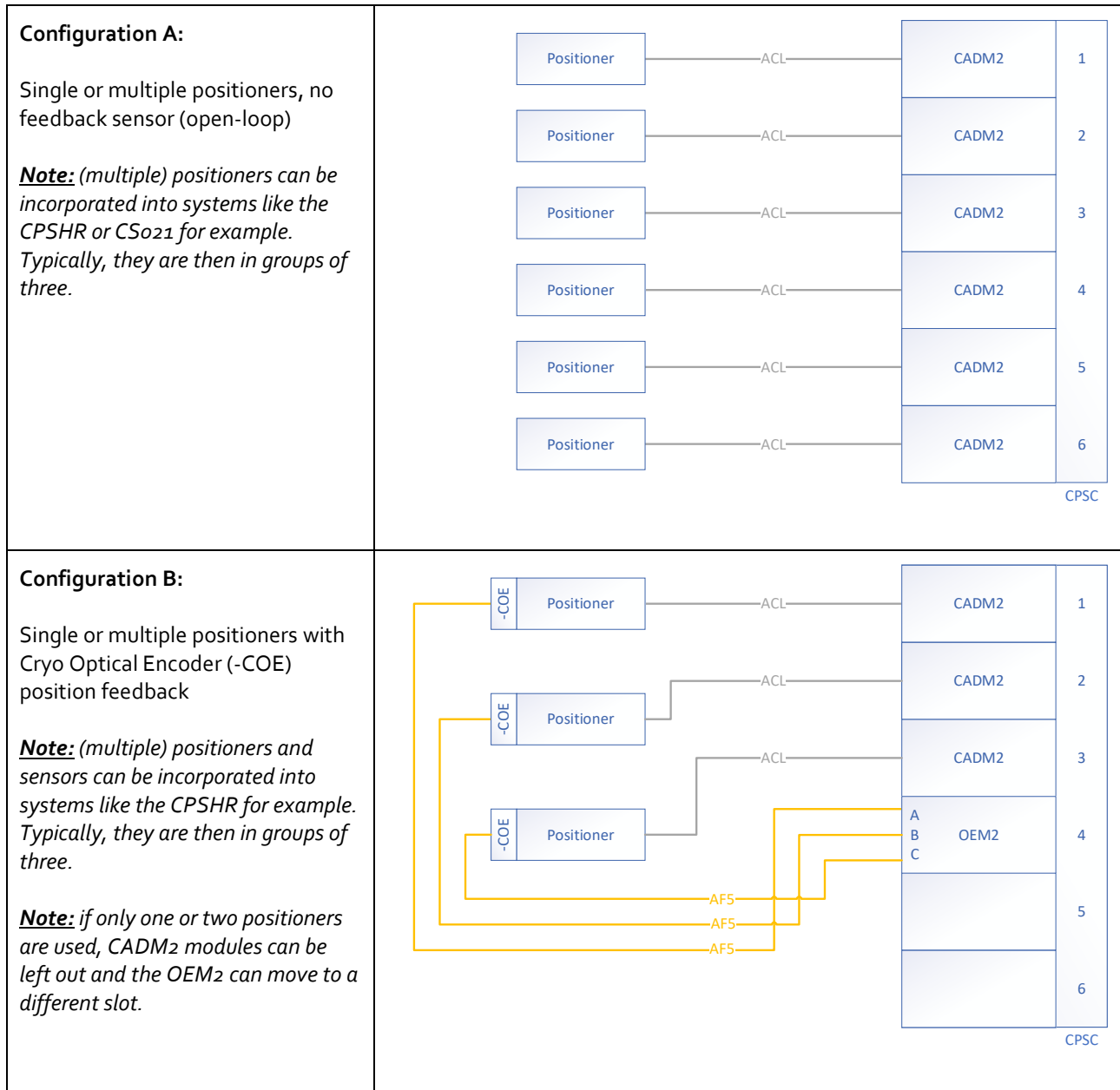

APPLICATION NOTE

CRYO & NANO PRODUCTS – CONNECTION OVERVIEW

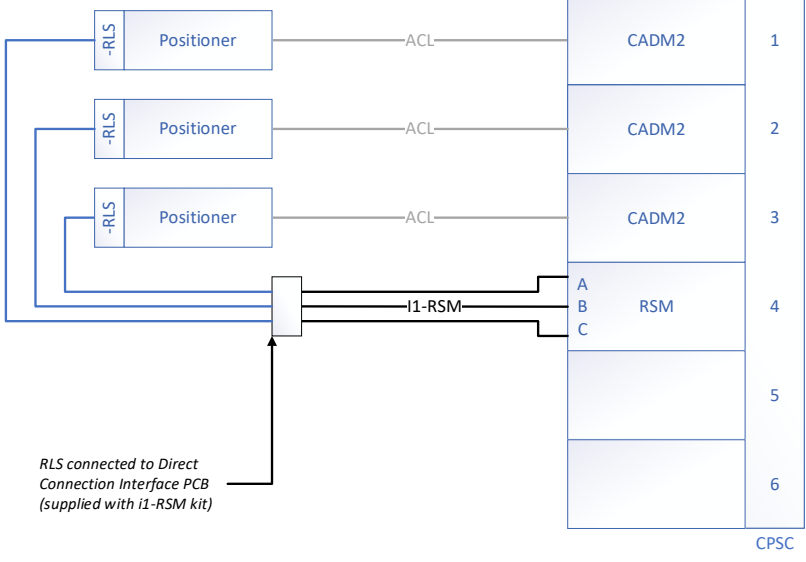
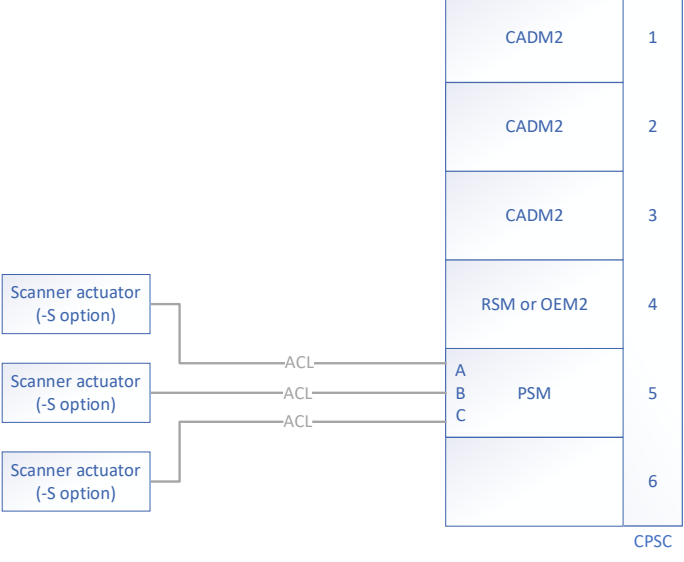
<p>Configuration C:</p> <p>Single or multiple positioners with Resistive Linear Sensor (-RLS) position feedback</p> <p>Note: (multiple) positioners and sensors can be incorporated into systems like the CS021 for example. Typically, they are then in groups of three.</p> <p>Note: if only one or two positioners are used, CADM2 modules can be left out and the RSM can move to a different slot.</p>	 <p>RLS connected to Direct Connection Interface PCB (supplied with i1-RSM kit)</p>
<p>Configuration D:</p> <p>Single or multiple <u>scanner</u> positioners (-S option)</p> <p>Note: PSM is typically installed in Slot 5, but this is not a requirement.</p> <p>Note: if a scanner positioner has an RLS, this can be routed to an RSM module. However, any closed-loop control needs to be implemented by the user at a higher level.</p>	 <p>RLS connected to Direct Connection Interface PCB (supplied with i1-RSM kit)</p>

APPLICATION NOTE

CRYO & NANO PRODUCTS – CONNECTION OVERVIEW

3. FEEDTHROUGH CONNECTION SETUP

Note: in this scenario the customer only needs to arrange matching cryo/vacuum feedthroughs to connect positioners to the controller and, if necessary cryo/vacuum optical wiring.

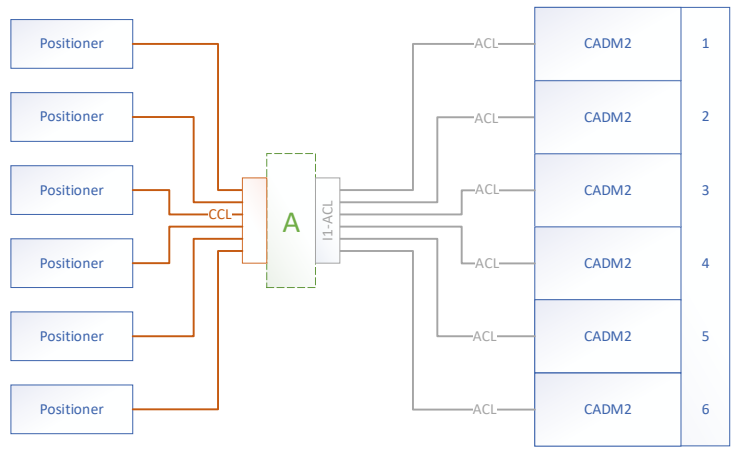
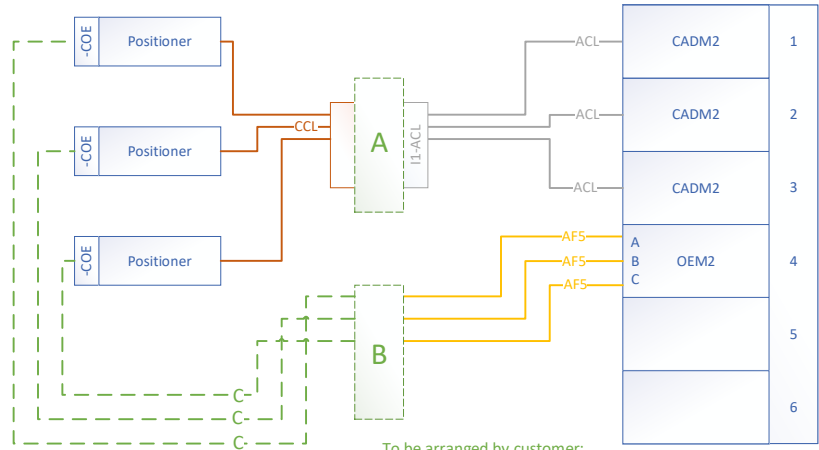
<p>Configuration A:</p> <p>Single or multiple positioners, no sensor feedback (open-loop)</p> <p>Note: (multiple) positioners can be incorporated into systems like the CPSHR or CS021 for example. Typically, they are then in groups of three.</p> <p>Note: the CCL can be ordered as CCL6 for up to 3 positioners or CCL12 for up to 6 positioners.</p>	 <p>To be arranged by customer: A: 15p male-male D-Sub Cryo/vacuum Feedthrough</p> <p style="text-align: right;">CPSC</p>
<p>Configuration B:</p> <p>Single or multiple positioners with Cryo Optical Encoder (-COE) position feedback</p> <p>Note: (multiple) positioners and sensors can be incorporated into systems like the CPSHR for example.</p> <p>Note: if only one or two positioners are used, CADM2 modules can be left out and the OEM2 can move to a different slot.</p> <p>Note: the CCL can be ordered as CCL6 for up to 3 positioners or CCL12 for up to 6 positioners.</p>	 <p>To be arranged by customer: A: 15p male-male D-Sub Cryo/vacuum Feedthrough B: Optical cryo/vacuum Feedthrough C: Cryo/vacuum optical fibers</p> <p style="text-align: right;">CPSC</p>

APPLICATION NOTE

CRYO & NANO PRODUCTS – CONNECTION OVERVIEW

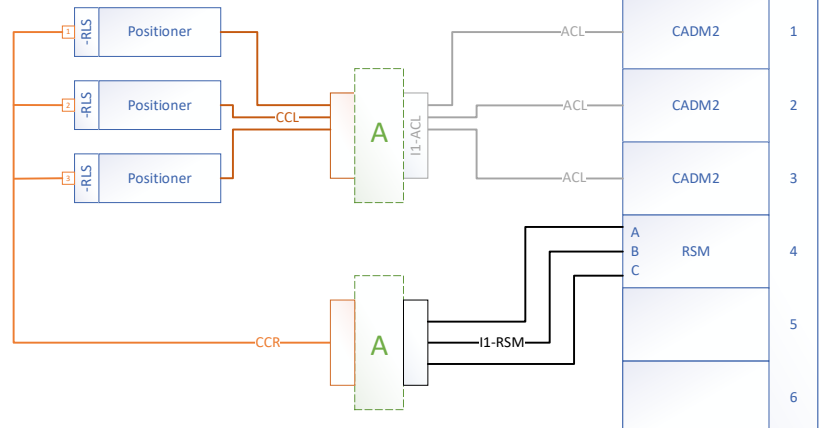
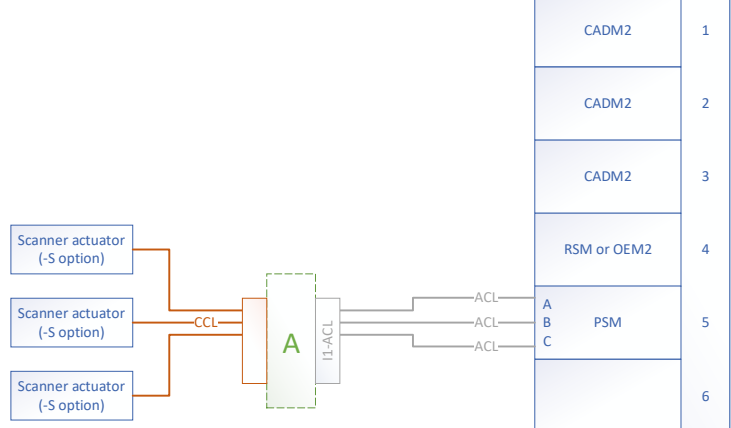
<p>Configuration C:</p> <p>Single or multiple positioners with Resistive Linear Sensor (-RLS) position feedback</p> <p>Note: (multiple) positioners and sensors can be incorporated into systems like the CS021 for example.</p> <p>Note: if only one or two positioners are used, CADM2 modules can be left out and the RSM can move to a different slot.</p> <p>Note: the CCL can be ordered as CCL6 for up to 3 positioners or CCL12 for up to 6 positioners.</p>	 <p>To be arranged by customer: A: (2x) 15p male-male D-Sub Cryo/vacuum Feedthrough CPSC</p>
<p>Configuration D:</p> <p>Single or multiple <u>scanner</u> positioners (-S option)</p> <p>Note: PSM is typically installed in Slot 5, but this is not a requirement.</p> <p>Note: if a scanner positioner has an RLS, this can be routed to an RSM module. However, any closed-loop control needs to be done at a higher level (implemented by user).</p> <p>Note: the CCL can be ordered as CCL6 for up to 3 positioners or CCL12 for up to 6 positioners.</p>	 <p>To be arranged by customer: A: 15p male-male D-Sub Cryo/vacuum Feedthrough CPSC</p>

APPLICATION NOTE

CRYO & NANO PRODUCTS – CONNECTION OVERVIEW

4. CONNECTION SETUP BY CUSTOMER

Note: if the connection solutions as described in the previous chapters are not suitable or desired, customers are free to arrange, manufacture or assemble their own wiring to connect to different types of feedthroughs for example. Please note that JPE can only offer limited support for this connection setup. Consult Chapter 5 (Interface & cabling) of the CNP Getting Started Guide (MANoo) for additional information.

4.1 AKE1 – Accessory Kit Electrical 1

To support customers with their own custom cabling, JPE can offer an accessory kit that contains typically used electrical connectors and interfaces to extend wiring, for example this kit contains a handful of small (17 x 11 mm) ZIF to solder pads breakout boards (FPC with 0.6mm stiffener) to connect Resistive Linear Sensors (-RLS) to customer wiring.

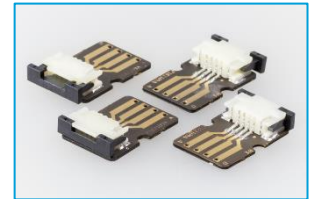

Consult Chapter 5.1 (Electrical components) of the CNP Getting Started Guide (MANoo) for a list of parts that are included in the AKE1.